

NLII-CO2-R-5 | Combined sensor CO₂/RH

Room sensor NLII-CO2 is used to continuously monitor air quality inside buildings and then control ventilation (HVAC) systems according to current levels of air internal air quality. The sensor measures concentration of carbon dioxide (CO₂) and relative humidity (RH) in air. It is suitable for offices, classrooms, shopping centers, homes, restaurants, fitness centers, commercial buildings, etc.

- › measures CO₂ and RH
- › LED indication with automatic turn off according to ambient light (at night)
- › 2x analog voltage/current output
- › 2x output relay – 2x NO/C
- › option for cascade relay switching
- › not required maintenance during operation
- › long life and stability



Type of sensor / order code	CO ₂ output	RH output	Relay
NLII-CO2-R-5	0-10 V/0-20 mA/4-20 mA ¹⁾	-	1x NO/C/NC
NLII-CO2+RH-R-5	0-10 V/0-20 mA/4-20 mA ¹⁾	0-10 V/0-20 mA/4-20 mA ¹⁾	2x NO/C

¹⁾ It is possible to select the desired type of analog output by a jumper. Minimum achievable output value corresponds to minimum value of the measuring range.

Description:

The measuring of CO₂ is based on the principle of infrared radiation attenuation dependence on the CO₂ concentration in the air (NDIR). Built-in auto-calibration function ensures very good long term stability.

Measurement of the relative humidity is based on the principle of capacitive polymer sensor.

The sensor has built-in two separate analog outputs - one for the actual concentration of CO₂ and the other for the current relative humidity.

If the sensor contains 2 relays, it can be set to two switching modes: standard (each relay switches according to its assigned quantity), a cascade mode (both relays switch according to one selected quantity and each one can be set to different switching level).

Cascade switching, for example, can be used to two-step switching of ventilation units output power. Relay trigger levels can be set independently by two rotary elements.

So the sensor efficiently manages ventilation and heat recovery units, based on current room air quality. The current air quality can easily be determined by looking at the three LED indicators. The **eco** level means good indoor air quality necessary to achieve a sense of well-being and at the same time optimal energy costs for heating, ventilation or air conditioning. Based on these measurements, ventilation, air conditioning and heat recovery units can be controlled directly in an efficient manner.

Explanation of abbreviations and technical terms can be found on our website in the [Glossary](#) section.



NLII-CO2-R-5 | Combined sensor CO₂/RH

Table of parameters

Parameter	Value	Unit
Supply voltage range	12 – 35	V DC
	12 – 24	V AC
Average consumption	0,5	W
CO ₂ measuring range	400 – 5000	ppm
CO ₂ accuracy	± 35 ppm ± 5 % of reading	
CO ₂ relay - hysteresis	100	ppm
CO ₂ rate rise	max 1	min
CO ₂ step response	(90 %) 80	s
RH measuring range	0 – 100 %	RH
RH accuracy 0 – 90 %	± 5 %	RH
RH accuracy 90 – 100 %	± 6 %	RH
RH switching hysteresis	5 %	RH
Max. switching voltage	250/30	V AC / V DC
Max. switching current	5/5	A AC / A DC
Working humidity non condensing	0 – 95 %	RH
Working temperature no condensing	0 to +50	°C
Storage temperature	-20 to +60	°C
Expected lifetime	min. 10	years
Ingress protection	IP20	
Dimensions	90x80x31	mm

CO₂ sensor autocalibration function

[Autocalibration](#) compensates for long-term aging of the key components of the sensor. This function is available only during permanent power sensor.

Calibration during operation is not necessary.

Selected analog output values versus actual CO₂ concentration

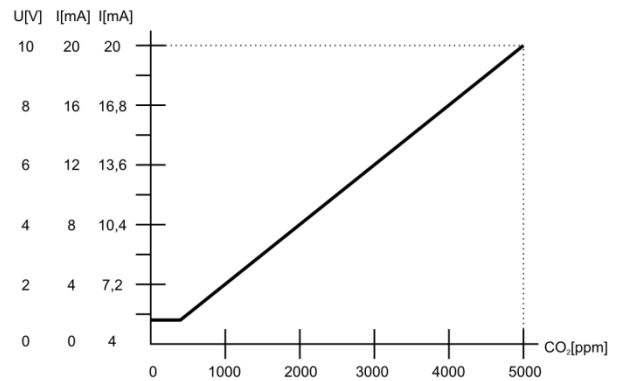

Selected analog output values versus actual RH

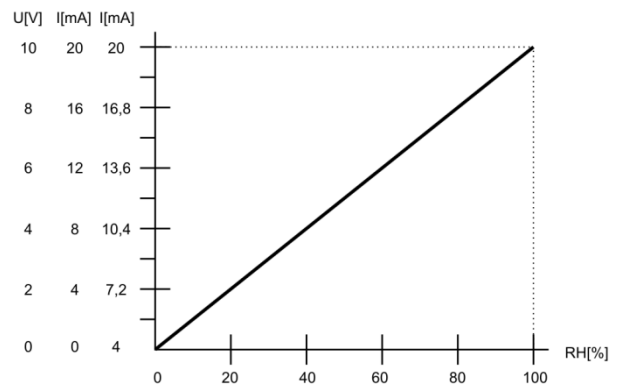

NLII-CO2-R-5 | Combined sensor CO₂/RH

LED indication description

White LED lights:

- 
- Less than 40 % RH or less than 600 ppm CO₂.
(according to the quantity selected for indication)
 - maintaining low concentrations of CO₂ is not cost-effective - slightly increased concentration does not cause any health complications
 - low concentrations of RH. Too dry air feels cooler as compared to equally hot but more humid air – risk of drying of the mucous membranes - respiratory problems

Green LED lights:

- 
- More than or equal to 40 % RH or 600 ppm CO₂,
less than or equal to 60 % RH or 1200 ppm CO₂.
(according to the quantity selected for indication)
 - optimal balance of air quality and energy efficiency of ventilation and air conditioning
 - optimal relative humidity for humans

Yellow LED lights:

- 
- More than 60 % RH or more than 1200 ppm CO₂.
(according to the quantity selected for indication)
 - higher concentration of CO₂ - further increase of CO₂ concentrations above this level can cause fatigue, restlessness, headache
 - too high humidity - the risk of mold growth and associated health complications

Sensor start after power on

All three LEDs flash simultaneously until the first readings are available, but no longer than 10 seconds.

Sensor failure indication

All three LEDs are shining permanently.

CAUTION:

Warm-up: operational after 1 minute since power on.
The declared accuracy is reached after 4 days of continuous power supply.

It is necessary to avoid severe mechanical shock of the sensor.



NLII-CO2-R-5 | Combined sensor CO₂/RH

Electronic board controls and terminals

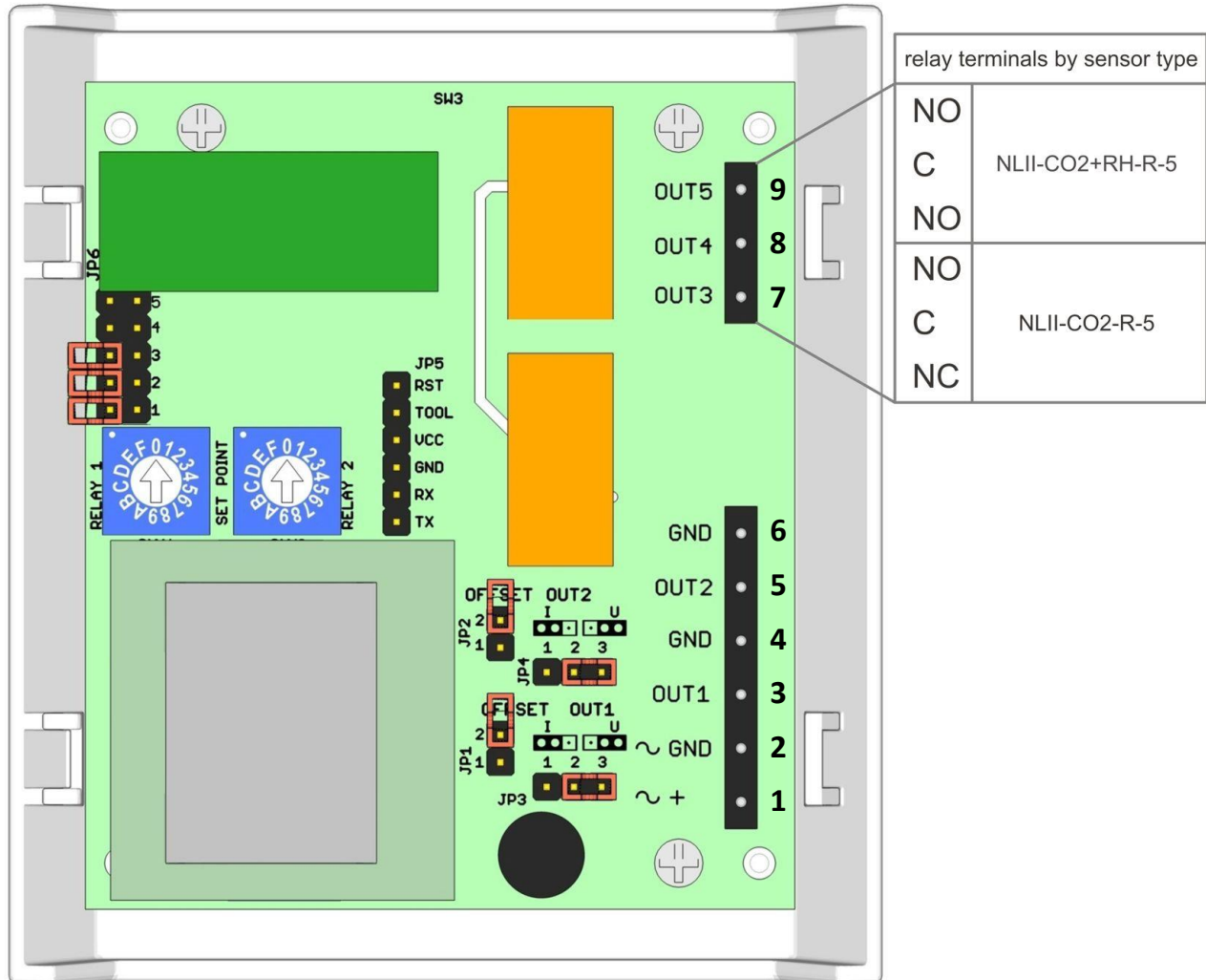

Terminals

- 1. ~ + power AC or DC (+) plus pole
- 2. ~ GND power AC or DC (-) minus pole, GND
- 3. OUT1 CO₂ sensor analog output, 0-10 V or 0-20 mA or 4-20 mA
- 4. GND CO₂ sensor output GND
- 5. OUT2 RH sensor analog output, 0-10 V or 0-20 mA or 4-20 mA
- 6. GND RH sensor output GND
- 7. OUT3 NO relay 2 output, normally open (RH) (for NLII-CO2-R-5 it is a NC contact)
- 8. OUT4 relay C output, common contact
- 9. OUT5 NO relay 1 output, normally open (CO₂)

SET POINT rotary switches for setting the relays switching levels

- RELAY 1 – switching level for CO₂
- RELAY 2 – switching level for RH







Jumpers

- JP1 – Current output offset RH
- JP2 – Current output offset CO₂
- JP3 – Voltage/current output CO₂
- JP4 – Voltage/current output RH
- JP6 – LED indication and switching mode settings



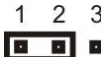























NLII-CO2-R-5 | Combined sensor CO₂/RH

Jumpers on the electronics board

Mark	Description	Settings	Meaning
JP1	Current output offset RH - shift quiescent current from 0 mA to 4 mA	2 ■ 1 ■	current output RH 0-20 mA
		2 ■ 1 ■ 	current output RH 4-20 mA
JP2	Current output offset CO₂ - shift quiescent current from 0 mA to 4 mA	2 ■ 1 ■	current output CO ₂ 0-20 mA
		2 ■ 1 ■ 	current output CO ₂ 4-20 mA
JP3	Voltage/current output CO₂ - select the type of analog output - if the selected voltage output is CO ₂ , JP2 must not be shorted	1 2 3 ■ 	voltage output CO ₂
		1 2 3 	current output CO ₂
JP4	Voltage/current output RH - select the type of analog output - if the selected voltage output is RH, JP1 must not be shorted	1 2 3 ■ 	voltage output RH
		1 2 3 	current output RH
JP6 - 1	Enabling LED indication - LED indication according to ambient light - when ambient light is dimmed (at night), LED indicators turn off automatically.	■ ■ 5 ■ ■ 4 ■ ■ 3 ■ ■ 2 	permanent LED indication enabled
		■ ■ 5 ■ ■ 4 ■ ■ 3 ■ ■ 2 ■ ■ 1	LED indication according to ambient light



NLII-CO2-R-5 | Combined sensor CO₂/RH

Mark	Description	Settings	Meaning
JP6 - 2 JP6 - 3	<p>Switching mode setting - standard/cascade. Selecting the sensor for switching and LED indication - CO₂ or RH.</p> <p>- if the standard switching is selected, CO₂ and RH sensor control their own relay</p> <p>- if cascade switching is selected, the one chosen sensor controls both relays according to the levels set by the SET POINT rotary switches (for both switches the according switching levels table - CO₂ or RH, is applied)</p>	 5  4  3  2  1	switching and LED indication by CO ₂ standard mode switching
 5  4  3  2  1		switching and LED indication by RH standard mode switching	
 5  4  3  2  1		switching and LED indication by CO ₂ cascade mode switching	
 5  4  3  2  1		switching and LED indication by RH cascade mode switching	
JP6 - 4 JP6 - 5		<p>These positions are not intended for user setting.</p>	 5  4  3  2  1



NLII-CO2-R-5 | Combined sensor CO₂/RH

Setting the relay switching using rotary switch SET POINT

The relay contact close when the measured quantity level rises above the level set on the SET POINT rotary switch. The relay contact open when the measured quantity level falls below the level set on the SET POINT rotary switch minus hysteresis value of 100 ppm. Minimal delay between relays state change is 2 minutes.

Standard switching one relay (NLII-CO2-R-5)

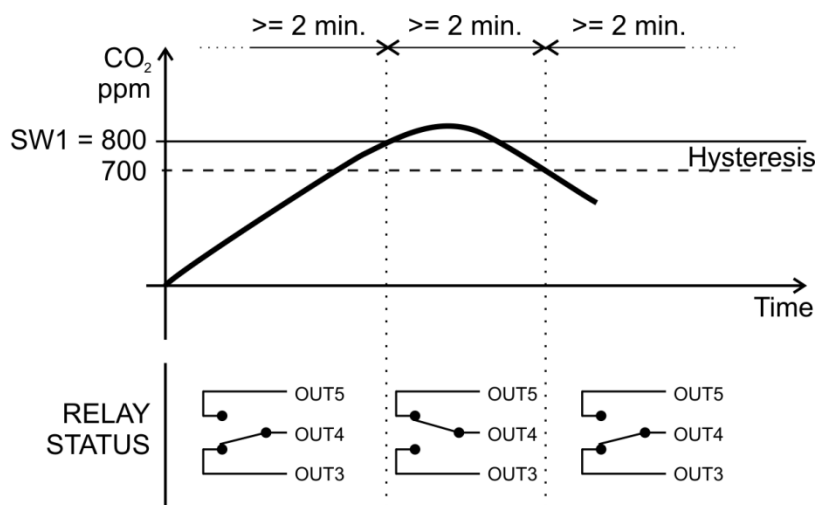

Standard switching with two relays by CO₂ (NLII-CO2+RH-R-5)

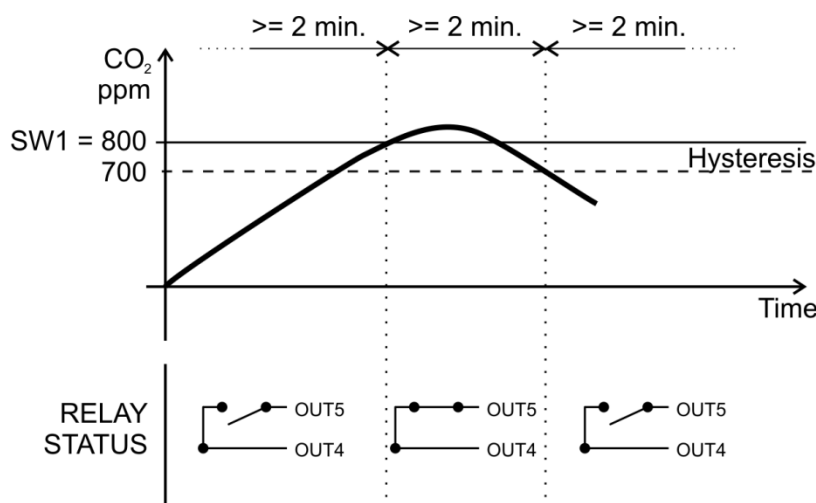

NLII-CO2-R-5 | Combined sensor CO₂/RH

Standard switching with two relays by RH (NLII-CO2+RH-R-5)

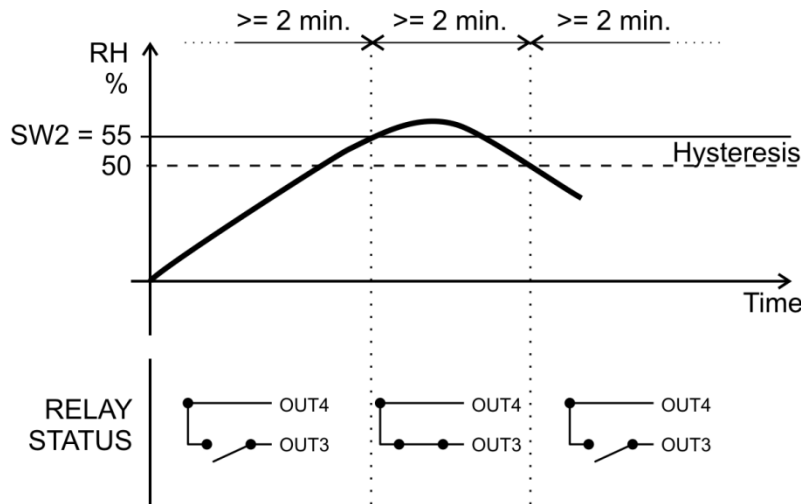

Cascade switching with two relays by CO₂ (NLII-CO2+RH-R-5)

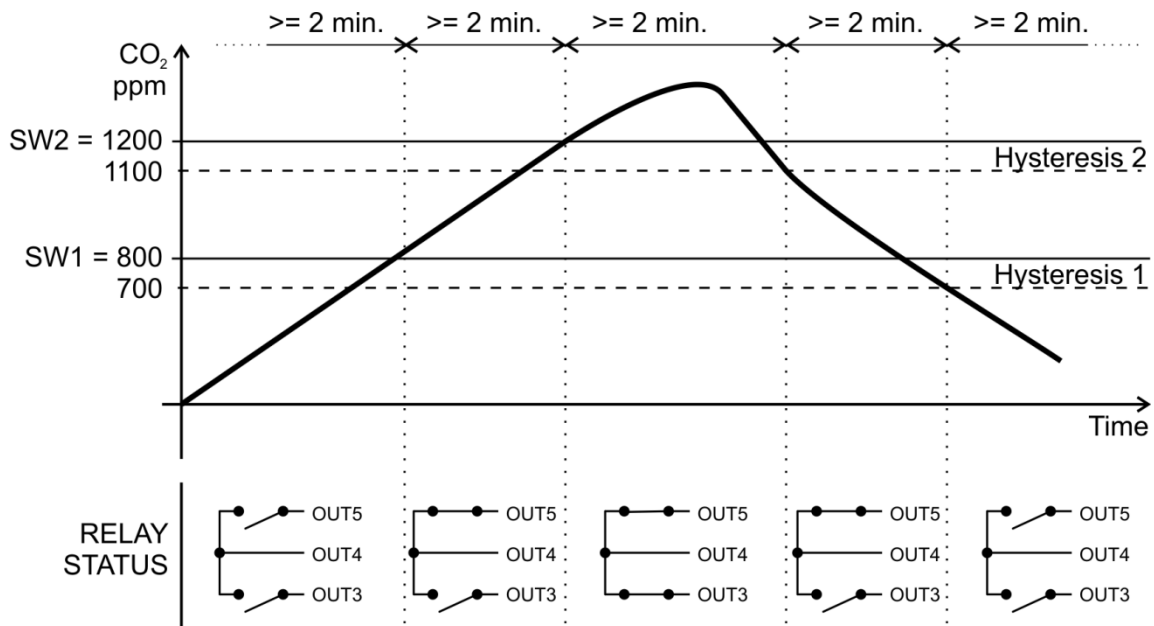

NLII-CO2-R-5 | Combined sensor CO₂/RH

Setting switching levels

Required concentration of CO₂

SET POINT	CO ₂ [ppm]
0	500
1	800
2	1100
3	1400
4	1700
5	2000
6	2300
7	2600
8	2900
9	3200
A	3500
B	3800
C	4100
D	4400
E	4700
F	5000

Required relative humidity (RH)

SET POINT	RH [%]
0	relay off
1	10
2	20
3	30
4	40
5	50
6	60
7	70
8	80
9	90
A	35
B	45
C	55
D	65
E	75
F	85

Example for setting the concentration of 2000 ppm:

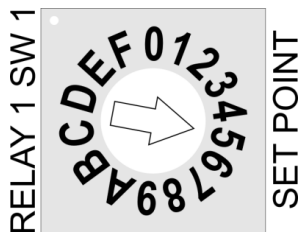

Example for setting a relative humidity of 55%:

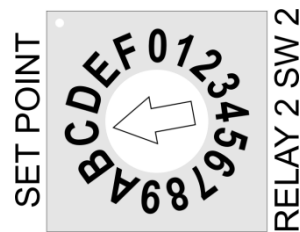

Factory settings

LED indication: by CO₂, indication turns off when ambient light dims
 CO₂ analog output: voltage output
 RH analog output: voltage output
 Relay switching mode: Standard
 Switching level CO₂: 2000 ppm
 Switching level RH: 55%



NLII-CO2-R-5 | Combined sensor CO₂/RH

Example of sensor connection CO₂ by one relay (1x switching contact)

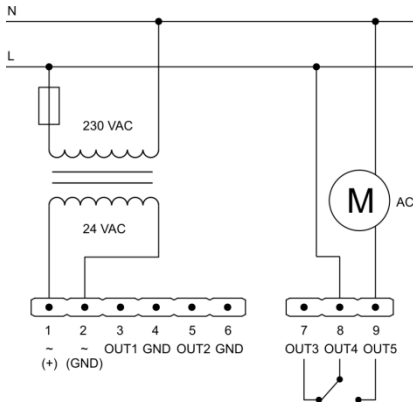

Example of sensor connection CO₂ for direct EC motor control using signal 0-10 V

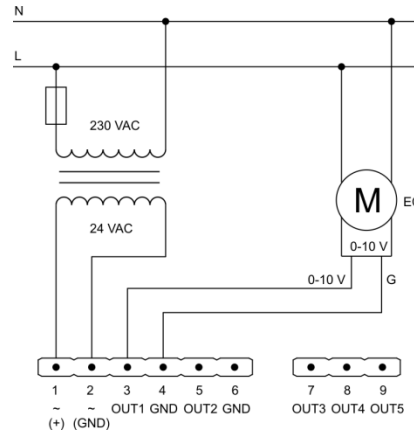

Example of sensor connection CO₂ with two relays (2x NO/C)

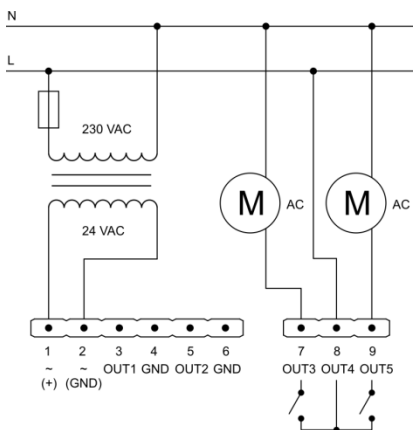

If you connect other devices to the same AC power source as the NL sensor, it is necessary to meet GND wiring of all analog inputs and outputs, as well as power wires.

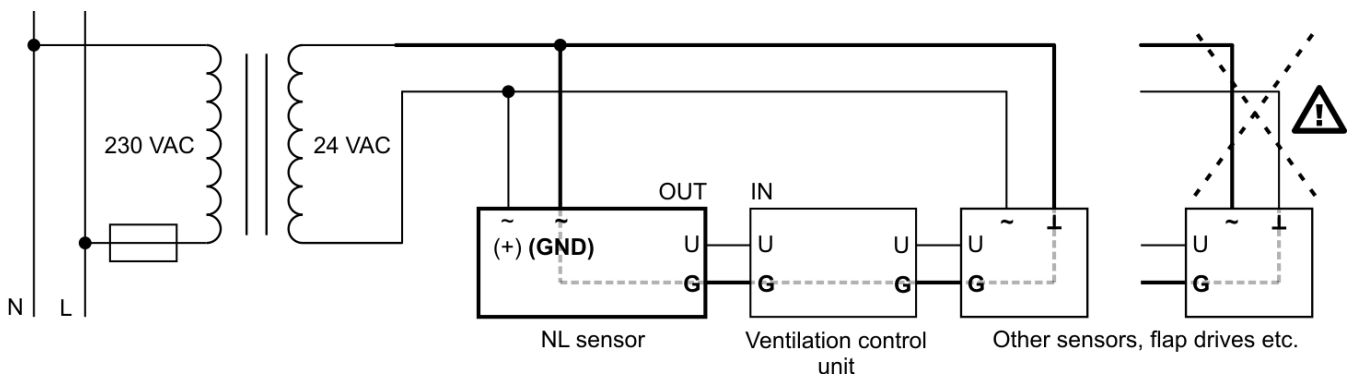

NLII-CO2-R-5 | Combined sensor CO₂/RH

Dimensions

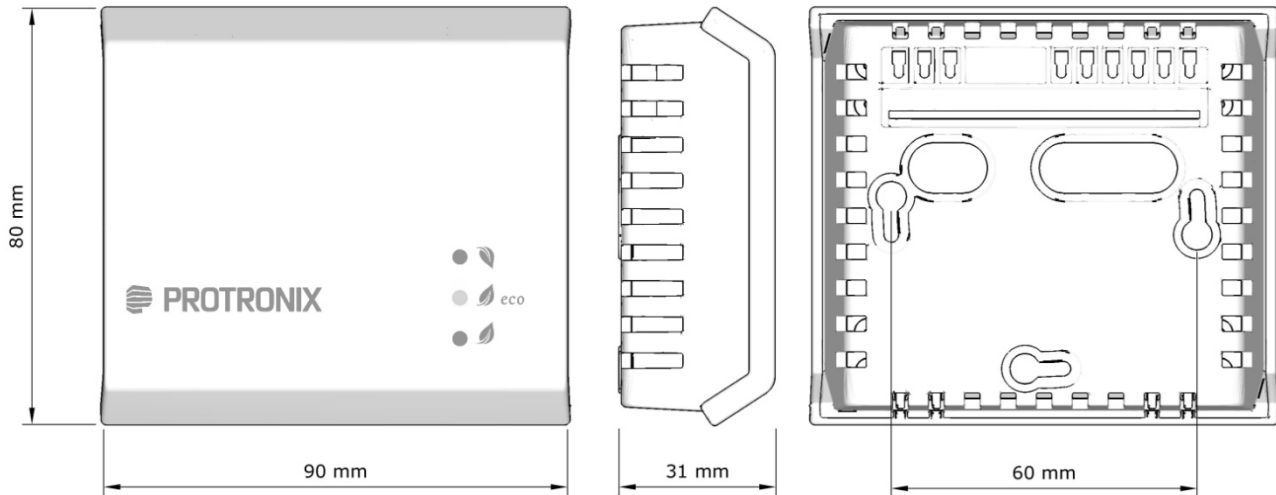

Sensor assembly



Box color

Front: white - RAL9016
Base: gray - RAL7035

Way to use

The product is intended for indoor use only. You can read the [recommendations for sensor placement](#) on our web pages.

End of product life

Discard the product according to the electronic waste law and the EU directives.

The producer reserves the right of technical changes in order to improve the product, its properties and functions, without previous notice.

